



# M9517-101

## 16 Channels, 200A, Power Distribution Unit

M9517-101 is a 16-channel power distribution unit, designed for land vehicle applications. It distributes 28VDC through overload and short-circuit protected switches. The M9517-101 supports CAN and RS-485 communication to control, configure and get the status of the device.



For product pricing and competitive lead times, contact our specialist Hi-Rel team:

0330 313 3220 | [hi-rel@apcplc.com](mailto:hi-rel@apcplc.com)



## The main features of the M9517-101 are:

- User defined maximum current per channel – Current Limit
- Large capacitance charge capability
- 1 input 16 outputs Power distribution unit.
- Configurable current breaker per Switch – Overload Protection Switch
- I<sup>2</sup>t curve for overload switching delay duration
- Configurable turn-on sequence by card wakeup and by discrete input
- Meets MIL-STD-1275E
  - Steady state Voltage levels 6V - 33V
  - Surge 100V 50ms & Spike 250V 70μs
  - Reverse voltage protection for both card and consumers
- Meets MIL-STD- 461E/F
- Interface and control:
  - RS-485 interface
  - CAN interface
  - 5 Discrete inputs
  - 1 Discrete output (Trip error output)
  - Manual shutdown input

For product pricing and competitive lead times, contact our specialist Hi-Rel team:

**0330 313 3220** | [hi-rel@apcplc.com](mailto:hi-rel@apcplc.com)



## Specifications:

|                                 |                                    |   |
|---------------------------------|------------------------------------|---|
| <b>Input</b>                    | <b>Voltage</b>                     | 6 to 33VDC steady state.<br>Fully compliant with MIL-STD-1275E.   |
|                                 | <b>Surges and Spikes</b>           | IAW MIL-STD-1275A-E.<br>Input clamp at 65V for device and loads.  |
|                                 | <b>Reverse Polarity Protection</b> | Device and loads protected on occasion of reverse voltage application.  |
|                                 | <b>Under Voltage Lockout</b>       | Device and outputs turn off when input voltage drops below 5.5V.<br>Device turns back on when input voltage rises above 6V.   |
| <b>Outputs</b>                  | <b>Rating</b>                      | Low Current Output – 7.5A<br>Medium Current Output – 15A<br>High Current Output – 30A<br>See Outputs Rating Table.  |
|                                 | <b>Drop Voltage</b>                | 175mV maximum at rated current.   |
|                                 | <b>Overload Protection</b>         | Configurable from 2A up to outputs rated current with 5% accuracy.<br>Trip by I <sup>2</sup> t curve see overload curve.  |
|                                 | <b>Short Circuit Protection</b>    | Configurable from 10A to 125A with 20% accuracy.<br>Protection is active, preventing from the short to spread through system. See short circuit curve.  |
|                                 | <b>Capacitive Load Charge</b>      | 9mF @ Vin = 28V, I <sub>LIM</sub> = 13A<br>3.5mF @ Vin = 33V, I <sub>LIM</sub> = 125A<br>7mF @ Vin = 28V, I <sub>LIM</sub> = 20A<br>Option to charge much greater capacitance, consult factory. |
|                                 | <b>Paralleling Outputs</b>         | Outputs can be paralleled to achieve higher rated outputs.  |
| <b>Control &amp; Indication</b> | <b>CAN</b>                         | Bitrate of 250Kbps to 1Mbps.<br>Differential input resistance of 100KΩ.   |
|                                 | <b>RS-485</b>                      | Baudrate of 1200bps to 115200bps.<br>Differential input resistance of 100KΩ.<br>Differential driver output 2V to 3.37V<br>Input receiver threshold between 50mV to 200mV.                       |
|                                 | <b>Discrete Inputs</b>             | Three inputs for functionality control (RAT, DCI, BATTLE see overview)<br>Two default communication mode pins<br>Three address pins   |
|                                 | <b>Discrete Output</b>             | Has one fault indication (see overview)   |
|                                 | <b>Measurements</b>                | Input and outputs voltages<br>Outputs current<br>Device Temperature   |

For product pricing and competitive lead times, contact our specialist Hi-Rel team:

0330 313 3220 | [hi-rel@apcplc.com](mailto:hi-rel@apcplc.com)

APC Technology Group  
6 Stirling Park, Laker Road, Rochester, Kent ME1 3QR  
+44 (0)330 313 3220 • [info@apcplc.com](mailto:info@apcplc.com) • [www.apcplc.com](http://www.apcplc.com)



**Specifications (Cont.):**

|                    |   |  |
|--------------------|---|--|
| <b>Environment</b> | <b>Ambient Temperature</b>  | Non-operating ambient : -55°C to +125°C<br>Operating : -55°C to + 105°C. (at unit's edges)   |
|                    | <b>Humidity</b>   | Up to 95% RH, Per MIL-STD-810F, Method 507.4   |
|                    | <b>Salt-fog</b>   | Per MIL-STD-810F, Method 509.4   |
|                    | <b>Altitude</b>   | Method 500.4, Procedure I & II, 40,000 ft. and 70,000 ft. Operational  |
|                    | <b>Mechanical Shock</b>   | Saw-tooth, 40 g peak, 11 ms.   |
|                    | <b>Vibration</b>  | Figure 514.5C-17. General minimum integrity exposure. (1 hour per axis)  |
| <b>EMI</b>         | <b>MIL-STD-461G</b>   | CE101, CE102, CS101 CS114 (10 kHz to 400 MHz, Curve #5), CS115, CS116, RE101, RE102 (Fixed wing external), RS101 and RS103 (2 MHz to 18 GHz 50 V/m). All tests are at full load and in accordance with the provisions of MIL-STD-461G – with shielded signals. |
| <b>MTBF</b>        | 150,000 hours, calculated per MIL-STD-217F at +50 °C at wedge lock edge, Ground |  |
| <b>Weight</b>      | TBD   |  |
| <b>Connectors</b>  | Input and signals:<br>Output (two connectors):                                  | Positronic CBM24W7M570000/AA or eq<br>CBM8W8S570000/AA or eq.  |

**Output Rating Table:**

| Output | Current Rating |
|--------|----------------|
| 0      | 30A            |
| 1      | 30A            |
| 2      | 15A            |
| 3      | 30A            |
| 4      | 15A            |
| 5      | 7.5A           |
| 6      | 7.5A           |
| 7      | 7.5A           |
| 8      | 7.5A           |
| 9      | 7.5A           |
| 10     | 7.5A           |
| 11     | 15A            |
| 12     | 30A            |
| 13     | 15A            |
| 14     | 30A            |
| 15     | 30A            |

For product pricing and competitive lead times, contact our specialist Hi-Rel team:

0330 313 3220 | [hi-rel@apcplc.com](mailto:hi-rel@apcplc.com)



**Pin Assignment:**

| P1 - Input        |                   |
|-------------------|-------------------|
| CBM24W7M570000/AA |                   |
| Pin               | Function          |
| A1                | VIN               |
| A2                | VIN               |
| A3                | VIN               |
| A4                | VIN               |
| A5                | VIN               |
| A6                | VIN               |
| A7                | VIN_RTN           |
| 1                 | CAN_L             |
| 2                 | CAN_H             |
| 3                 | BATTLE_OVERRIDE_N |
| 4                 | DCI_N             |
| 5                 | BR1               |
| 6                 | BR2               |
| 7                 | ADDR_RTN          |
| 8                 | ADDR_1            |
| 9                 | FAULT_OUT         |
| 10                | ADDR_2            |
| 11                | RAT               |
| 12                | ADDR_3            |
| 13                | SHUTDOWN_N        |
| 14                | 28VDC_RTN         |
| 15                | COM_GND           |
| 16                | RS_485_P          |
| 17                | RS_485_N          |

| P2 - Output      |          |
|------------------|----------|
| CBM8W8S570000/AA |          |
| Pin              | Function |
| A1               | CH7_OUT  |
| A2               | CH6_OUT  |
| A3               | CH5_OUT  |
| A4               | CH4_OUT  |
| A5               | CH3_OUT  |
| A6               | CH2_OUT  |
| A7               | CH1_OUT  |
| A8               | CH0_OUT  |

| P3 - Output      |          |
|------------------|----------|
| CBM8W8S570000/AA |          |
| Pin              | Function |
| A1               | CH15_OUT |
| A2               | CH14_OUT |
| A3               | CH13_OUT |
| A4               | CH12_OUT |
| A5               | CH11_OUT |
| A6               | CH10_OUT |
| A7               | CH9_OUT  |
| A8               | CH8_OUT  |

For product pricing and competitive lead times, contact our specialist Hi-Rel team:

**0330 313 3220** | [hi-rel@apcplc.com](mailto:hi-rel@apcplc.com)



### Typical Characteristics

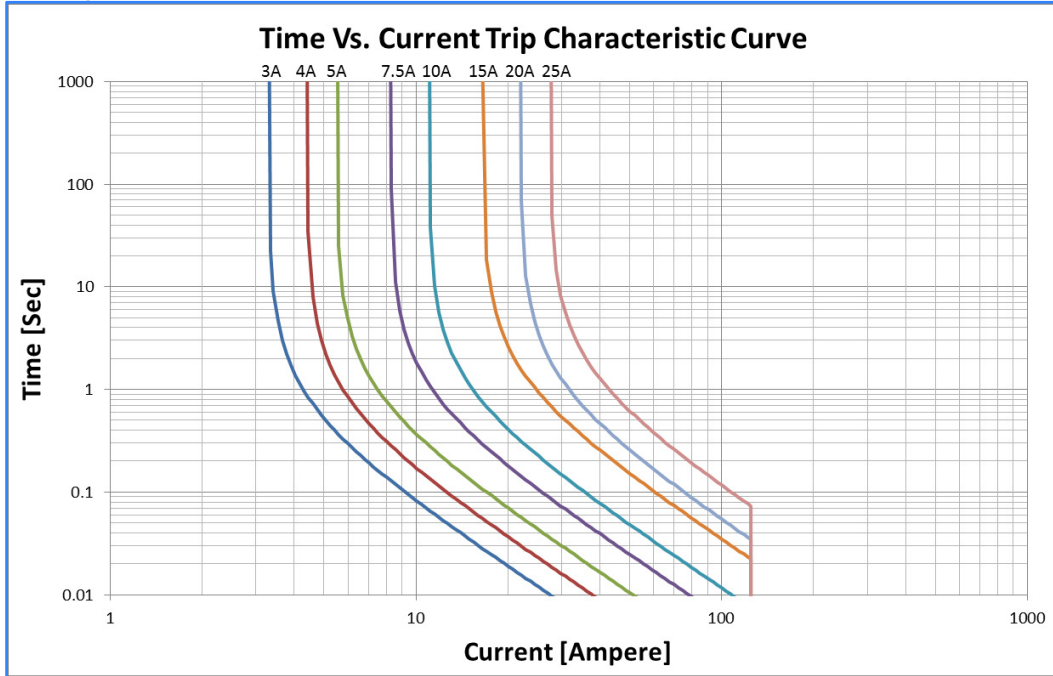

Figure 1 - Time vs. Current Overload Trip

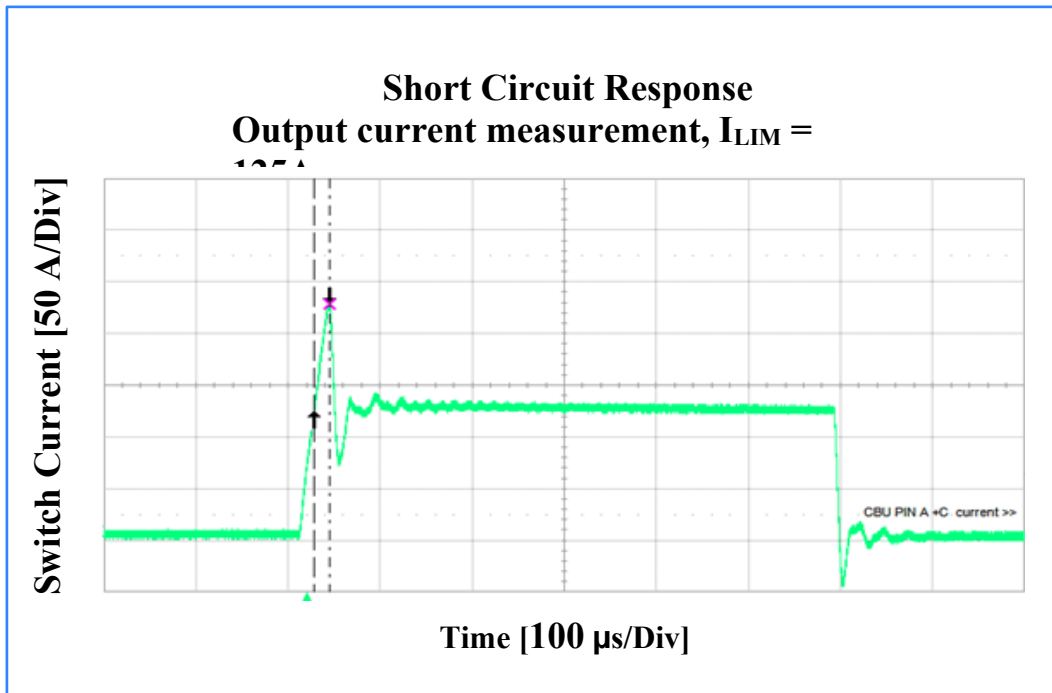

Figure 2 - Short Circuit Response

For product pricing and competitive lead times, contact our specialist Hi-Rel team:

**0330 313 3220** | [hi-rel@apcplc.com](mailto:hi-rel@apcplc.com)

## Overview

### Interface Description

#### POR

Power On Reset (POR) is a sequence of operations that happens automatically when device starts up. The PDU can start pre-defined switches automatically on POR and wait a predefined amount of time between each switch. The delay and sequencing options let the whole system to start smoothly with as low as possible stress.

To configure POR the user should send a macro command with element = 230 and State = 1. Later the user should send commands that support macros like switch on/off and delay. When complete the user should send the macro command again but with State = 0.

#### Discrete Inputs

M9517-1 has 3 discrete inputs which can help control the device:

BATTLE\_SHORT\_N - active low input signal. If active, then all outputs are switched to battle mode. Switch will not trip due to overload, but it will trip in case of short circuit. If short-circuit occur, then the switch will trip but will shortly resume in an auto retry mode.

DCI\_N – Transition from high to low will start a macro. Macro can enable or disable selected outputs. Each output can turn on or off in delay from previous output.

RAT –Transition from high to low will reset the trip status of all outputs.

Each input has the following interface:

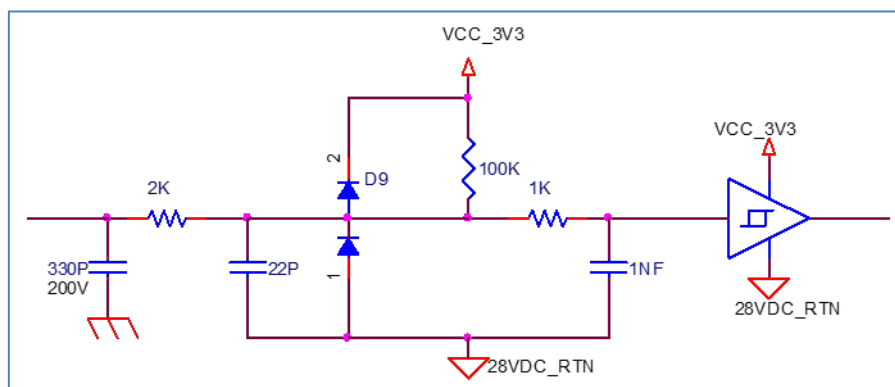

Figure 3 – Discrete input interface

#### Address Input

ADDR[3:1] – Address bits used for communication (see Communication Interface section) and for configuration loading. On startup the address is set for communication and one of the 8 possible configurations is loaded according to Page Mapping command.

For product pricing and competitive lead times, contact our specialist Hi-Rel team:

0330 313 3220 | [hi-rel@apcplc.com](mailto:hi-rel@apcplc.com)

Each address input has the following interface:

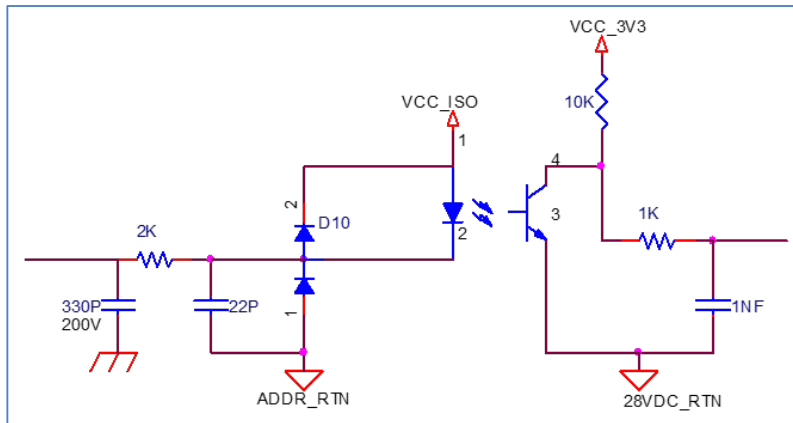

Figure 4 – Address input interface

### Discrete Outputs

FAULT\_OUT is active low signal, if any of the outputs trip, then the FAULT\_OUT signal is shorted to 28VDC\_RTN.

FAULT\_OUT has the following interface:

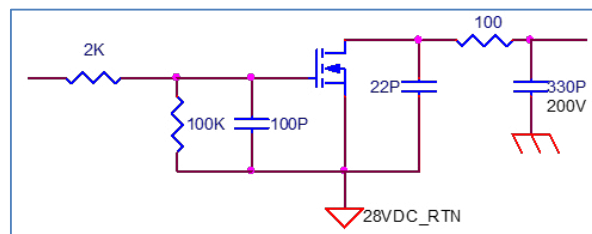

Figure 5 – Fault output interface

### Shutdown Pin

SHUTDOWN\_N is active low input signal. If shorted to 28VDC\_RTN then the internal VCC of the device will drop causing a complete shutdown and minimal quiescent current.

SHUTDOWN\_N interface:

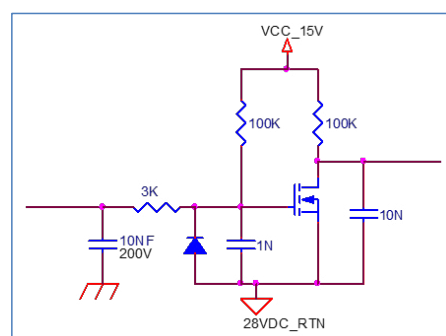

Figure 6 – Shutdown input interface

For product pricing and competitive lead times, contact our specialist Hi-Rel team:

0330 313 3220 | [hi-rel@apcplc.com](mailto:hi-rel@apcplc.com)





## Communication Interface

### RS-485 Messages

#### Message Structure

The communication is ASCII coded. Every RS-485 packet starts with ':' char and ends with '\r\n' chars. Message format is:

| Parameter  | Description   | Values   | Type     |
|------------|---|--|----------|
| Start Byte | Each packet start with this byte. If previous message didn't complete receiving it will be discarded. | ':' (0x3A)   | char     |
| Address    | Address to which the message is intended.   | {0b110,ADDR[3:1],0b00}   | UInt8    |
| Type       | The purpose of the message.   | 0x65 – RS-485 Configuration<br>0x67 – All other messages                 | UInt8    |
| Payload    | The payload data of the message   | If Type is 0x65 see below<br>If type is 0x67 see Message Payload section | UInt8[8] |
| Checksum   | Message error detection checksum byte   | See calculation  | UInt8    |
| End Bytes  | Each packet ends with these bytes.  | '\r\n' (0x0D0A)  | Char[2]  |

#### Payload for 0x65 messages

0x65 message is used to configure the RS-485 protocol parameters. Payload structure is:

| Parameter | Description  | Values                          | Type     |
|-----------|--|---------------------------------|----------|
| Baudrate  | Baud rate to be used in none default mode.<br>Formula: $2995200 / (\text{Baudrate in bps})$      | 26 - 2496<br>Default is 156     | UInt16   |
| Parity    | Parity selected  | 0 – None<br>1 – Even<br>2 – Odd | UInt8    |
| Timeout   | Byte timeout for which a message will be discarded.<br>Formula: $(\text{time in seconds}) * 0.1$ | 1 – 50<br>Default is 10         | UInt8    |
| Null      | Not used bytes   | Don't care                      | UInt8[4] |

#### Checksum calculation

Checksum is calculated without the start and end bytes, the sum of the bytes modulo 256 should be zero.

For product pricing and competitive lead times, contact our specialist Hi-Rel team:

0330 313 3220 | [hi-rel@apcplc.com](mailto:hi-rel@apcplc.com)



## CAN BUS Messages

### Message Structure

The PDU is using SAE J1939 over CAN. The CAN ID structure for all messages sent to PDU is:

|                |               |               |                         |
|----------------|---------------|---------------|-------------------------|
| 0xC77E         | ADDR[3:1]     | 0x0           | Source Computer Address |
| Length 16 bits | Length 3 bits | Length 2 bits | Length 8 bits           |

Followed by Control set for data frame and 8 bytes of data.

CAN ID for return messages from PDU will be:

|                |                         |               |               |               |
|----------------|-------------------------|---------------|---------------|---------------|
| 0x18EF         | Source Computer Address | 0x6           | ADDR[3:1]     | 0x0           |
| Length 13 bits | Length 8 bits           | Length 3 bits | Length 3 bits | Length 2 bits |

Followed by Control set for data frame and 8 bytes of data.

Alert messages will be with the following CAN ID format:

|                |               |               |               |
|----------------|---------------|---------------|---------------|
| 0x18FFF1       | 0x6           | ADDR[3:1]     | 0x0           |
| Length 21 bits | Length 3 bits | Length 3 bits | Length 2 bits |

Followed by Control set for data frame and 8 bytes of data.

The Data bytes for CAN message are the same as the payload bytes for 0x67 RS-485 messages and appear in the Message Payload section.

For product pricing and competitive lead times, contact our specialist Hi-Rel team:

**0330 313 3220** | [hi-rel@apcplc.com](mailto:hi-rel@apcplc.com)



## Message Payload

### Payload general structure

The data is in format of little-endian. Payload structure to both CAN and RS-485 Messages:

| Parameter | Description   | Values   | Type   |
|-----------|---|--|--------|
| OpCode    | A code to specify the command   | Odd number x for command<br>Even number x+1 for response | Uint8  |
| Status    | A field applicable to response only notifying the execution status of the command.                | See Status Values table                                  | Bit[6] |
| R/W       | A flag to set the command as write or read or macro command. Not all opcodes have all the options | 0 – Read<br>1 – Write<br>2 – Macro                       | Bit[2] |
| Data      | A data related to the opcode. If data is less than 6 bytes, then it will be padded with zeros.    | See next paragraphs                                      |        |

Status values and meaning:

Table 1 - Status values

| Status Value | Description  |
|--------------|--|
| 0x00         | Successful execution                                 |
| 0x01         | General R/W error                                    |
| 0x02         | Read not supported for opcode                        |
| 0x03         | Write not supported for opcode                       |
| 0x05         | Error writing to flash                               |
| 0x07         | Wrong element selected                               |
| 0x08         | Channel number doesn't exist                         |
| 0x09         | Group number doesn't exist                           |
| 0x0A         | Sensor doesn't exist                                 |
| 0x0B         | Board doesn't exist                                  |
| 0x0C         | Wrong address  |
| 0x0D         | Wrong page   |
| 0x14         | Wrong State  |
| 0x17         | Wrong flash index                                    |
| 0x18         | Wrong flash key                                      |
| 0x20         | Group is empty                                       |
| 0x30         | Current limit or overload threshold is out of bounds |
| 0x3E         | Opcode doesn't exist                                 |
| 0x3F         | General Error  |

For product pricing and competitive lead times, contact our specialist Hi-Rel team:

0330 313 3220 | [hi-rel@apcplc.com](mailto:hi-rel@apcplc.com)



## Controls

### **Channel Control 1**

The command turns on or off a channel or a group. If selected write command than the channel or group will be affected immediately. If selected as part of macro sequence than the channel or group will be affected when macro is triggered.

| Parameter | Description  | Values  | Type   |
|-----------|--|---|--------|
| OpCode    | A code to specify the command  | 0x01 for command<br>0x02 for response           | UInt8  |
| Status    | A field applicable to response only notifying the execution status of the command. | See Status Values table                         | Bit[6] |
| R/W       | A flag to set the command as write or read or macro command.                       | 1 – Write<br>2 – Macro                          | Bit[2] |
| Element   | The Channel or group to control  | Channel 0-99 : 0 – 99<br>Group 0-49 : 100 - 149 | UInt8  |
| State     | Turn on or off selection   | 0 – Turn off<br>1 – turn on                     | UInt8  |

### **Channel Control 2**

The command enables or disables battle mode for channel or a group. When enabled, the channel or group will disconnect due to over load. In case of short circuit, the switch will disconnect only if overheated and after it cools it will retry. If selected write command than the channel or group will be affected immediately. If selected as part of macro sequence than the channel or group will be affected when macro is triggered.

| Parameter | Description  | Values  | Type   |
|-----------|--|---|--------|
| OpCode    | A code to specify the command  | 0x03 for command<br>0x04 for response               | UInt8  |
| Status    | A field applicable to response only notifying the execution status of the command. | See Status Values table                             | Bit[6] |
| R/W       | A flag to set the command as write or read or macro command.                       | 1 – Write<br>2 – Macro                              | Bit[2] |
| Element   | The Channel or group to control  | Channel 0-99 : 0 – 99<br>Group 0-49 : 100 - 149     | UInt8  |
| Battle    | Battle mode enable disable   | 0x00 – Disable<br>0x0D – Enable<br>Else – No action | UInt8  |

For product pricing and competitive lead times, contact our specialist Hi-Rel team:

**0330 313 3220** | [hi-rel@apcplc.com](mailto:hi-rel@apcplc.com)



### Reset

The command resets the device immediately.

| Parameter | Description  | Values                                | Type   |
|-----------|--|---------------------------------------|--------|
| OpCode    | A code to specify the command  | 0x07 for command<br>0x08 for response | UInt8  |
| Status    | A field applicable to response only notifying the execution status of the command. | See Status Values table               | Bit[6] |
| R/W       | A flag to set the command as write or read or macro command.                       | 1 – Write                             | Bit[2] |

### Status

#### Channel Status 1

| Parameter | Description  | Values  | Type   |
|-----------|--|---|--------|
| OpCode    | A code to specify the command  | 0x21 for command<br>0x22 for response           | UInt8  |
| Status    | A field applicable to response only notifying the execution status of the command. | See Status Values table                         | Bit[6] |
| R/W       | A flag to set the command as write or read or macro command.                       | 0 – Read  | Bit[2] |
| Element   | The Channel or group to control  | Channel 0-99 : 0 – 99<br>Group 0-49 : 100 - 149 | UInt8  |
| Current   | Current of selected channel or group   | Current = Value*0.01 – 80,000                   | UInt24 |
| Voltage   | Voltage of selected channel or group   | Voltage = Value*0.05 – 1,606                    | UInt16 |

#### Channel Status 2

| Parameter | Description  | Values                                | Type   |
|-----------|--|---------------------------------------|--------|
| OpCode    | A code to specify the command  | 0x25 for command<br>0x26 for response | UInt8  |
| Status    | A field applicable to response only notifying the execution status of the command. | See Status Values table               | Bit[6] |
| R/W       | A flag to set the command as write or read or macro command.                       | 0 – Read                              | Bit[2] |
| Element   | The Channel or group to control  | Channel 0-99 : 0 – 99                 | UInt8  |

For product pricing and competitive lead times, contact our specialist Hi-Rel team:

0330 313 3220 | [hi-rel@apcplc.com](mailto:hi-rel@apcplc.com)



|          |   | Group 0-49 : 100 - 149                            |        |
|----------|---|---|--------|
| SwState  | Switch physical state   | 0 – Off<br>1 - On                                 | Bit[2] |
| CmdState | Switch commanded state  | 0 – Off<br>1 - On                                 | Bit[2] |
| OutputV  | Output voltage is greater than 60% of input   | 0 – Voltage is low<br>1 – Voltage is high         | Bit[2] |
| OutputI  | Output current is greater than 30% of overload setting current  | 0 – Current is high<br>1 – Current is high        | Bit[2] |
| Trip     | Trip status of output   | 0 – No trip has occurred<br>1 – Trip has occurred | Bit[2] |
| BIT      | BIT Status of selected output. Bit is asserted when output voltage doesn't appear when switch is supposed to be on (on command and no trip) or when voltage or current appear when switch is supposed to be off (off command or trip) | 0 – Normal<br>1 - Error                           | Bit[2] |
| Battle   | Battle status of output   | 0 – Normal<br>1 – Battle                          | Bit[2] |
| Group    | Group of selected output  | 0 – 50 when grouped<br>251 – when not grouped     | Uint8  |
| N\A      | For future use  |   | Uint8  |
| N\A      | For future use  |   | Bit[6] |
| Sharing  | Status of current distribution between to switches of same group. Asserted when more than 10% difference between switches   | 0 – OK<br>1 – Current isn't shared                | Bit[2] |

For product pricing and competitive lead times, contact our specialist Hi-Rel team:

0330 313 3220 | [hi-rel@apcplc.com](mailto:hi-rel@apcplc.com)



### *Input Status*

| Parameter | Description  | Values                                | Type   |
|-----------|--|---------------------------------------|--------|
| OpCode    | A code to specify the command  | 0x27 for command<br>0x28 for response | Uint8  |
| Status    | A field applicable to response only notifying the execution status of the command. | See Status Values table               | Bit[6] |
| R/W       | A flag to set the command as write or read or macro command.                       | 0 – Read                              | Bit[2] |
| Element   | Selection of input   | 190                                   | Uint8  |
| Current   | Current of selected channel or group   | Current = Value*0.01 – 80,000         | Uint24 |
| Voltage   | Voltage of selected channel or group   | Voltage = Value*0.05 – 1,606          | Uint16 |

### *Temperature*

| Parameter   | Description  | Values                                | Type   |
|-------------|--|---------------------------------------|--------|
| OpCode      | A code to specify the command  | 0x33 for command<br>0x34 for response | Uint8  |
| Status      | A field applicable to response only notifying the execution status of the command. | See Status Values table               | Bit[6] |
| R/W         | A flag to set the command as write or read or macro command.                       | 0 – Read                              | Bit[2] |
| Element     | Selection of input   | 152                                   | Uint8  |
| Temperature | Board temperature in degrees centigrade  | Temp. = Value*0.03125 – 273           | Uint16 |

For product pricing and competitive lead times, contact our specialist Hi-Rel team:

**0330 313 3220** | [hi-rel@apcplc.com](mailto:hi-rel@apcplc.com)



### Grouped Channels

| Parameter  | Description  | Values   | Type   |
|------------|--|--|--------|
| OpCode     | A code to specify the command  | 0x35 for command<br>0x36 for response  | UInt8  |
| Status     | A field applicable to response only notifying the execution status of the command. | See Status Values table  | Bit[6] |
| R/W        | A flag to set the command as write or read or macro command.                       | 0 – Read   | Bit[2] |
| Element    | Selection of input   | Group 0-49 : 100 - 149   | UInt8  |
| N\A        | For future use   |  | UInt8  |
| Channel_0  | Channel 0 membership to the specified group  | 0 – Channel 0 is not part of the group<br>1 - Channel 0 is part of the group   | Bit[2] |
| Channel_1  | Channel 1 membership to the specified group  | 0 – Channel 1 is not part of the group<br>1 - Channel 1 is part of the group   | Bit[2] |
|            |  |  |        |
| Channel_15 | Channel 15 membership to the specified group                                       | 0 – Channel 15 is not part of the group<br>1 - Channel 15 is part of the group | Bit[2] |

For product pricing and competitive lead times, contact our specialist Hi-Rel team:

**0330 313 3220** | [hi-rel@apcplc.com](mailto:hi-rel@apcplc.com)





## Configuration

### Channel Setting

| Parameter | Description  | Values  | Type   |
|-----------|--|---|--------|
| OpCode    | A code to specify the command  | 0x61 for command<br>0x62 for response           | Uint8  |
| Status    | A field applicable to response only notifying the execution status of the command.                   | See Status Values table                         | Bit[6] |
| R/W       | A flag to set the command as write or read or macro command.   | 0 – Read<br>1 – Write                           | Bit[2] |
| Element   | Selection of input   | Channel 0-99 : 0 – 99<br>Group 0-49 : 100 - 149 | Uint8  |
| OverLoad  | Overload threshold setting, where I2T curve is active  | Current = Value*0.01 – 80,000                   | Uint24 |
| CLimit    | Current limit threshold setting, where active current limit is applied to protect from short circuit | Current = Value*0.5                             | Uint16 |

### Calibration

| Parameter | Description  | Values  | Type     |
|-----------|--|---|----------|
| OpCode    | A code to specify the command  | 0x67 for command<br>0x68 for response   | Uint8    |
| Status    | A field applicable to response only notifying the execution status of the command. | See Status Values table   | Bit[6]   |
| R/W       | A flag to set the command as write or read or macro command.                       | 1 – Write   | Bit[2]   |
| Element   | Selection of channel   | Channel 0-99 : 0 – 99   | Uint8    |
| CalType   | Calibration type   | 0 – Offset Calibration<br>1 – Current Slope<br>2 – Voltage Slope<br>3 – Factory Setting | Uint8    |
| Data      | Data relative to CalType field   | See table below   | Uint8[3] |

For product pricing and competitive lead times, contact our specialist Hi-Rel team:

0330 313 3220 | [hi-rel@apcplc.com](mailto:hi-rel@apcplc.com)



| R/W   | CalType            | Data   |
|-------|--------------------|--|
| Write | Offset calibration | If channel is off then an offset calibration is performed for current and voltage management. Data will be ignored<br>If channel is off then the message will return Error 0x3F(General) |
| Write | Current Slope      | Data[3:0] – the current measured externally formatted as<br>value = Current*100 + 8,000,000  |
| Write | Voltage Slope      | Data[3:0] – the voltage measured externally formatted as<br>value = Voltage*20 + 32,120  |
| Write | Factory Setting    | Set to Factory setting. Data is ignored.   |

### Save Configuration

| Parameter | Description  | Values                                | Type   |
|-----------|--|---------------------------------------|--------|
| OpCode    | A code to specify the command  | 0x71 for command<br>0x72 for response | UInt8  |
| Status    | A field applicable to response only notifying the execution status of the command. | See Status Values table               | Bit[6] |
| R/W       | A flag to set the command as write or read or macro command.                       | 1 – Write                             | Bit[2] |
| FlashPage | Flash page where current configuration will be saved                               | 0 - 7                                 | UInt8  |
| MagicNum  | Magic number to enable configuration save  | 0xACAB                                | UInt16 |

For product pricing and competitive lead times, contact our specialist Hi-Rel team:

0330 313 3220 | [hi-rel@apcplc.com](mailto:hi-rel@apcplc.com)



### Page Mapping

| Parameter | Description  | Values   | Type   |
|-----------|--|--|--------|
| OpCode    | A code to specify the command  | 0x73 for command<br>0x74 for response                | UInt8  |
| Status    | A field applicable to response only notifying the execution status of the command. | See Status Values table                              | Bit[6] |
| R/W       | A flag to set the command as write or read or macro command.                       | 0 – Read<br>1 – Write                                | Bit[2] |
| Address   | Address for the flash page to link to.   | 0 - 7  | UInt8  |
| Page      | Flash page to link to Address  | 0 – 7  | UInt8  |
| Page_2    | Flash page to link to Address+1  | 0 – 7 – in order to link<br>255 – in order to ignore | UInt8  |
| Page_3    | Flash page to link to Address+2  | 0 – 7 – in order to link<br>255 – in order to ignore | UInt8  |
| Page_4    | Flash page to link to Address+3  | 0 – 7 – in order to link<br>255 – in order to ignore | UInt8  |
| Page_5    | Flash page to link to Address+4  | 0 – 7 – in order to link<br>255 – in order to ignore | UInt8  |

### Group Setting

| Parameter | Description  | Values                                  | Type   |
|-----------|--|---|--------|
| OpCode    | A code to specify the command  | 0x81 for command<br>0x82 for response   | UInt8  |
| Status    | A field applicable to response only notifying the execution status of the command. | See Status Values table                 | Bit[6] |
| R/W       | A flag to set the command as write or read or macro command.                       | 0 - Read<br>1 – Write                   | Bit[2] |
| Element   | Selection of Channel   | Channel 0-99 : 0 – 99                   | UInt8  |
| Group     | Number of group for selected Channel   | Group 0-49 : 100 – 149<br>Ungroup : 251 | UInt8  |

For product pricing and competitive lead times, contact our specialist Hi-Rel team:

0330 313 3220 | [hi-rel@apcplc.com](mailto:hi-rel@apcplc.com)



| R/W   | CalType            | Data   |
|-------|--------------------|--|
| Write | Offset calibration | If channel is off than an offset calibration is performed for current and voltage management. Data will be ignored<br>If channel is off than the message will return Error 0x3F(General) |
| Write | Current Slope      | Data[3:0] – the current measured externally formatted as<br>value = Current*100 + 8,000,000  |

### Macro Record

| Parameter | Description  | Values   | Type   |
|-----------|--|--|--------|
| OpCode    | A code to specify the command  | 0x83 for command<br>0x84 for response  | UInt8  |
| Status    | A field applicable to response only notifying the execution status of the command. | See Status Values table  | Bit[6] |
| R/W       | A flag to set the command as write or read or macro command.                       | 1 – Write  | Bit[2] |
| Element   | Selection of element to configure macro to   | POR – 230<br>DCI - 194   | UInt8  |
| State     | Macro Start and stop options   | 0 – Stop Recording<br>1 – Start Recording high triggered macro<br>2 – Start Recording low triggered macro<br>3 – Change macro mask | UInt8  |

### Delay (For Macro Use)

| Parameter | Description  | Values                                | Type   |
|-----------|--|---------------------------------------|--------|
| OpCode    | A code to specify the command  | 0x85 for command<br>0x86 for response | UInt8  |
| Status    | A field applicable to response only notifying the execution status of the command. | See Status Values table               | Bit[6] |
| R/W       | A flag to set the command as write or read or macro command.                       | 1 – Write                             | Bit[2] |
| Delay     | Delay time in milliseconds   |                                       | UInt16 |

For product pricing and competitive lead times, contact our specialist Hi-Rel team:

0330 313 3220 | [hi-rel@apcplc.com](mailto:hi-rel@apcplc.com)



**Dimensions:**

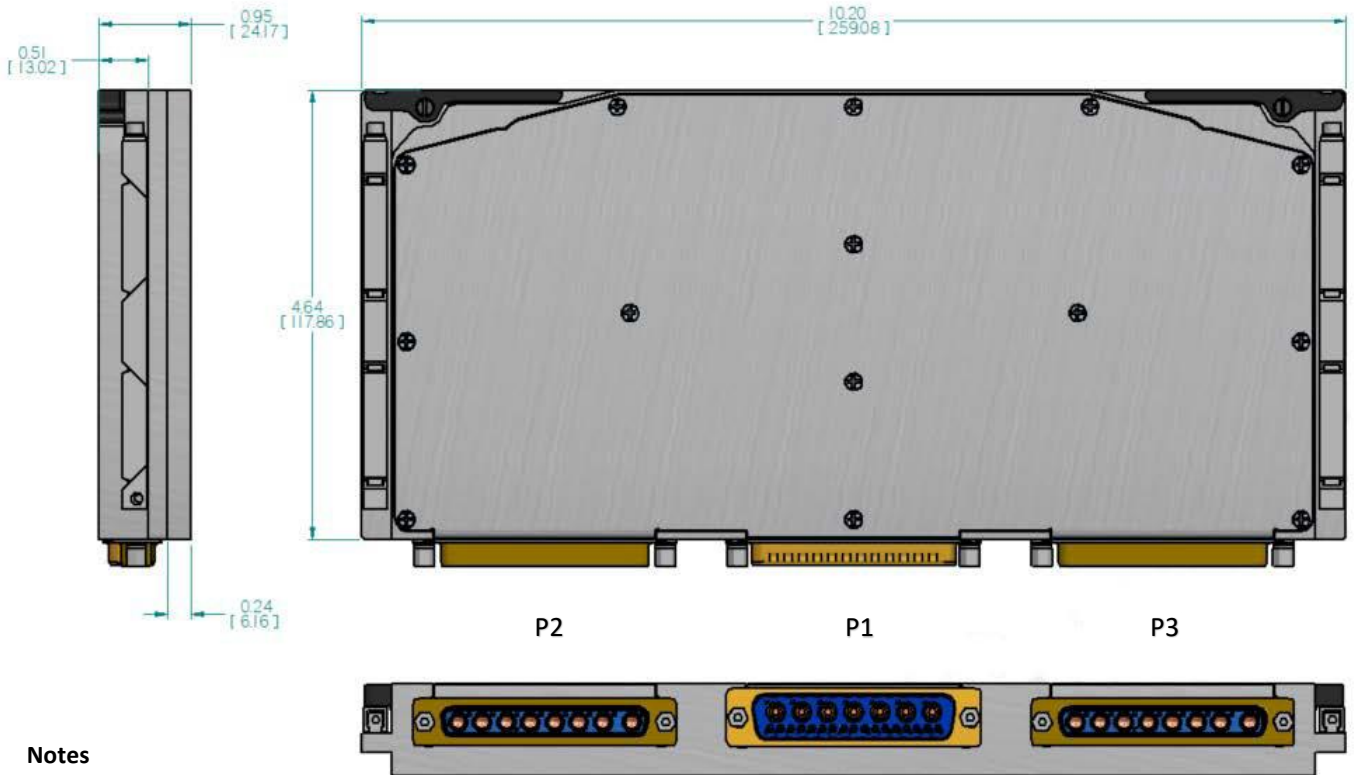

**Notes**

1. Dimensions are in inches [mm]
2. Tolerance is:  
 .XX ±0.01 in  
 .XXX ±0.005 in
3. Weight: Approx. 3.3 lb [1.5 kg]
4. This figure is for reference only.

For product pricing and competitive lead times, contact our specialist Hi-Rel team:

**0330 313 3220** | [hi-rel@apcplc.com](mailto:hi-rel@apcplc.com)