

ARINC 429 PRODUCT SELECTOR GUIDE

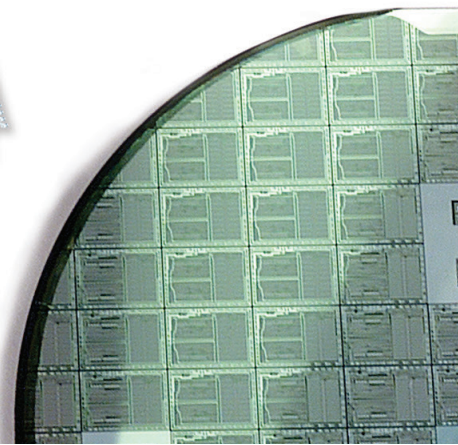
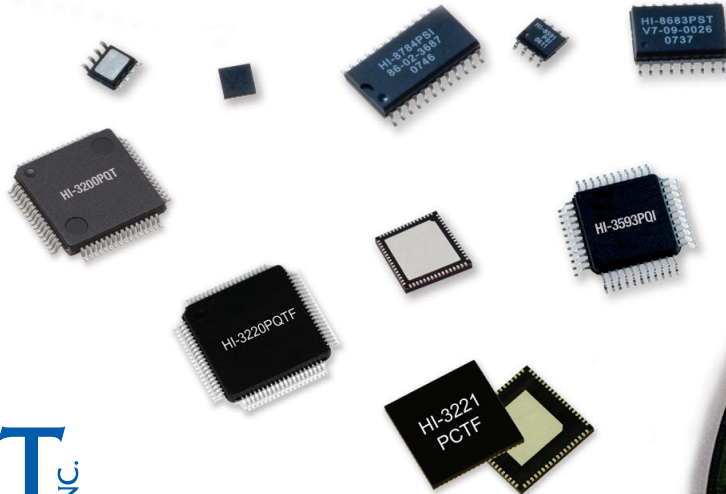

HOLT INC.
INTEGRATED CIRCUITS

ARINC 429 ICs

Part Number ¹	Tx/Rx Channels	Tx FIFO (Words)	Rx FIFO (Words)	Label Filter Depth	Host Interface	Data Sheet	Integrated Line Driver	Integrated Line Receiver(s)	Test Mode ²	Tri State Output	Internal Lightning Protection ⁷	Supply Voltages		Packages ^{3,4}
												Digital	Line Driver	
SPI Interface Protocol ICs														
HI-35930	1/2	32	32	256	SPI Serial	HI-35930	1	2	Y	N	Y	3.3V	3.3V	1, 2
HI-35981	1/8	32	32	256	SPI Serial	HI-35981	-	8	Y	N	N	3.3V OR 5V	-	19
HI-3220	8/16	32K Bytes RAM		256	40MHz SPI Serial	HI-3220	-	16	Y	Y	N	3.3V	-	24
HI-3221	8/16	32K Bytes RAM		256	40MHz SPI Serial		-	16	Y	Y	N	3.3V	-	25
HI-3222	4/8	32K Bytes RAM		256	40MHz SPI Serial		-	8	Y	Y	N	3.3V	-	2
HI-3210	4/8	32K Bytes RAM		256	SPI Serial	HI-3210	-	-	Y	N	N	3.3V	-	3, 19
HI-35850	1/1	32	32	256	SPI Serial	HI-3585	1	1	Y	N	N	3.3V OR 5V	± 5V	1, 2
HI-35870	1/0	32	-	-	SPI Serial	HI-3587	1	-	N	N	N	3.3V OR 5V	± 5V	1, 2
HI-35880	0/1	-	32	256	SPI Serial	HI-3588	-	1	N	N	N	3.3V OR 5V	-	1, 2
HI-35960-40	1/8	-	4	16	SPI Serial	HI-3598	-	8	Y	N	N	3.3V OR 5V	-	2
HI-35970-40	1/7	-	4	16	SPI Serial	HI-3598	-	7	Y	N	N	3.3V OR 5V	-	5
HI-35980	1/8	-	4	16	SPI Serial	HI-3598	-	8	Y	N	N	3.3V OR 5V	-	3, 4
HI-35990-40	0/8	-	4	16	SPI Serial	HI-3598	-	8	Y	N	N	3.3V OR 5V	-	2, 5
Parallel Interface Protocol ICs														
HI-3583A-15	1/2	32	32	16	16-bit-Parallel	HI-3583A	1	2	Y	N	N	3.3V	± 10V	3, 4, 6
HI-3584A-15	1/2	32	32	16	16-bit-Parallel	HI-3584A	-	2	Y	N	N	3.3V	-	3, 4, 6
ARINC 429 / ARINC 717 Transceiver														
HI-3718	1/1	-	-	-	-	HI-3718	1	1	N	Y	N	3.3V	-	8
Line Drivers														
HI-8598 ⁹	1/0	-	-	-	-	HI-8598	1	-	N	Y	N	+3.3V	+3.3V	27
HI-8597	1/0	-	-	-	-	HI-8597	1	-	N	Y	Y	-	+3.3V	23
HI-8596	1/0	-	-	-	-	HI-8596	1	-	N	Y	N	-	+3.3V	14, 15
HI-8592	1/0	-	-	-	-	HI-8592	1	-	N	Y	N	-	+5V	12, 13
HI-8594	1/0	-	-	-	-		1	-	N	Y	N	-	± 5V	9, 11
HI-8500/1/2	1/0	-	-	-	-	HI-8500	1	-	N	N	N	-	± 9.5V or ± 16.5V	9, 11
HI-8503/4/5	1/0	-	-	-	-		1	-	N	Y ⁹	N	-	± 9.5V or ± 16.5V	9, 11
HI-8506/7	1/0	-	-	-	-		1	-	N	Y ⁹	N	-	± 9.5V or ± 16.5V	26
Line Receivers														
HI-8450	0/1	-	-	-	-	HI-8450	-	1	Y	Y	Y	3.3V or 5V	-	18
HI-8451	0/1	-	-	-	-		-	1	Y	N	Y	3.3V or 5V	-	18
HI-8454	0/4	-	-	-	-		-	4	Y	N	Y	3.3V or 5V	-	7, 16
HI-8455	0/4	-	-	-	-		-	4	N	N	Y	3.3V or 5V	-	16
HI-8460 ⁹	0/1	-	-	-	-	HI-8460	-	1	Y	N	Y	3.3V or 5V	-	15, 18
ARINC 429 Repeater														
HI-35851	1/1	-	-	-	-	HI-35851	1	1	N	N	N	3.3V or 5V	± 5V	1

IC PACKAGES⁴

	Package	Material	SMD	Operating Temperature Range ⁵	Dimensions in Packages ⁶ (mm)
1	 QFP-44	Plastic	Y	I, T, M	0.52 x 0.52 x 0.106 (13.2 x 13.2 x 2.7)
2	 QFN-44	Plastic	Y	I, T, M	0.276x 0.276x 0.039 (7.0 x 7.0 x 1.0)
3	 QFN-64	Plastic	Y	I, T, M	0.354 x 0.354 x 0.039 (9.0 x 9.0 x 1.0)
4	 QFP-52	Plastic	Y	I, T, M	0.52 x 0.52 x 0.106 (13.2 x 13.2 x 2.7)
5	 SOIC-24 (Wide Body)	Plastic	Y	I, T, M	0.607 x 0.407 x 0.10 (15.392 x 10.325 x 2.6)
6	 CerQuad-52 (J-Lead)	Ceramic	Y	I, T, M	0.788 x 0.788 x 0.19 (20.0 x 20.0 x 4.826)
7	 QFN-32	Plastic	Y	I, T, M	0.197 x 0.197 x 0.039 (5.0 x 5.0 x 1.0)
8	 QFP-32	Plastic	Y	I, T, M	0.354 x 0.354 x 0.047 (9.0 x 9.0 x 1.2)
9	 ESDIP-8	Plastic	Y	I, T, M	0.193 x 0.236 x 0.052 (4.9 x 6.0 x 1.325)
10	 PDIP-8	Plastic	N	I, T, M	0.385 x 0.300 x 0.160 (9.799 x 7.620 x 4.064)
11	 CERDIP-8	Plastic	N	I, T, M	.380 x 0.314 x 0.2 (9.652 x 7.976 x 5.08)
12	 ESDIP-14 (Narrow Body)	Plastic	Y	I, T, M	0.341 x 0.236 x 0.069 (8.65 x 6.0 x 1.75)
13	 QFN-24	Plastic	Y	I, T	0.197 x 0.197 x 0.038 (5.0 x 5.0 x 0.96)

	Package	Material	SMD	Operating Temperature Range ⁵	Dimensions in Packages ⁶ (mm)
14	 SOIC-16 (Narrow Body)	Plastic	Y	I, T, M	0.390 x 0.236 x 0.056 (9.9 x 5.99 x 1.425)
15	 QFN-16	Plastic	Y	I, T, M	0.157 x 0.157 x 0.039 (4.0 x 4.0 x 1.0)
16	 TSSOP-20	Plastic	Y	I, T, M	0.256 x 0.252 x 0.04 (6.5 x 6.4 x 1.025)
17	 TSSOP-38	Plastic	Y	I, T, M	0.382 x 0.252 x 0.04 (9.70 x 6.40 x 1.025)
18	 SOIC-8	Plastic	Y	I, T, M	0.193 x 0.236 x 0.056 (4.9 x 6.0 x 1.425)
19	 LQFP-64	Plastic	Y	I, T, M	0.472 x 0.472 x 0.063 (12.0 x 12.0 x 1.6)
20	 LQFP-100	Plastic	Y	I, T, M	0.63 x 0.63 x 0.063 (16.0 x 16.0 x 1.6)
21	 TQFP-64	Plastic	Y	I, T, M	0.354 x 0.354 x 0.047 (9.0 x 9.0 x 1.2)
22	 LQFP-128	Plastic	Y	I, T, M	0.63 x 0.63 x 0.063 (16.0 x 16.0 x 1.6)
23	 ESDIP-16 (Wide Body)	Plastic	Y	I, T, M	0.406 x 0.406 x 0.089 (10.3 x 10.3 x 2.25)
24	 QFP-80	Plastic	Y	I, T, M	0.472 x 0.472 x 0.063 (12.0 x 12.0 x 1.6)
25	 QFN-72	Plastic	Y	I, T, M	0.394 x 0.394 x 0.039 (10.0 x 10.0 x 1.0)
26	 QFN-20	Plastic	Y	I, T, M	0.197 x 0.197 x 0.039 (5.0 x 5.0 x 1.0)
27	 SOIC-18 (Wide Body)	Plastic	Y	I, T, M	0.406 x 0.455 x 0.089 (10.3 x 11.55 x 2.25)

AUTONOMOUS (No MCU Required)

Part Number ¹	Tx/Rx Channels	Integrated Line Driver	Integrated Line Receiver(s)	Internal Lightning Protection ⁷	Supply Voltages		Packages ^{3, 4}
					Digital	Line Driver	
HI-8470	1/0	Y	-	Y	3.3V	3.3V	20
HI-8475	0/1	-	Y	Y	3.3V OR 5V	-	21
HI-8476	0/1	-	Y	Y	3.3V OR 5V	-	22
HI-8477	0/1	-	Y	Y	3.3V or 5V	-	21
HI-8478	0/1	-	Y	Y	3.3V or 5V	-	21

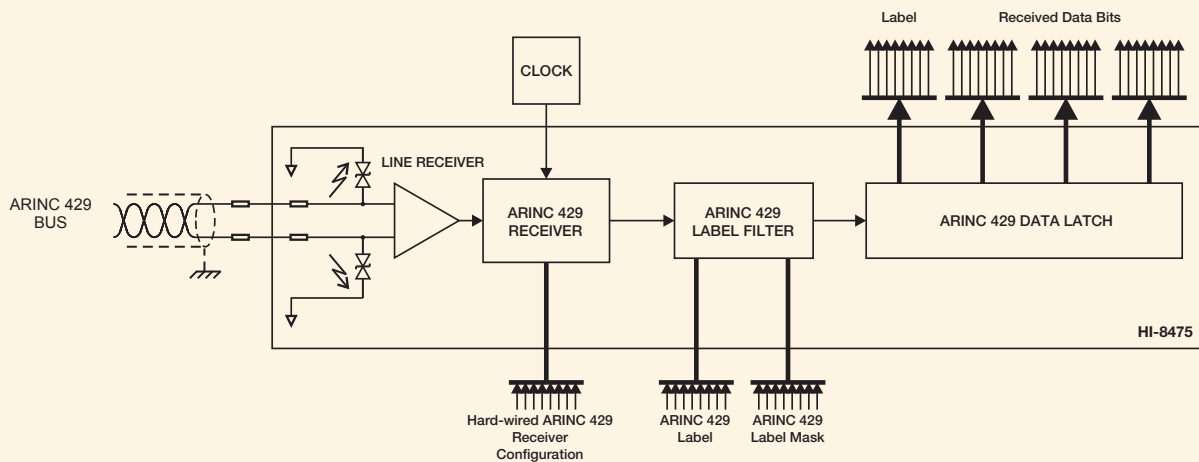
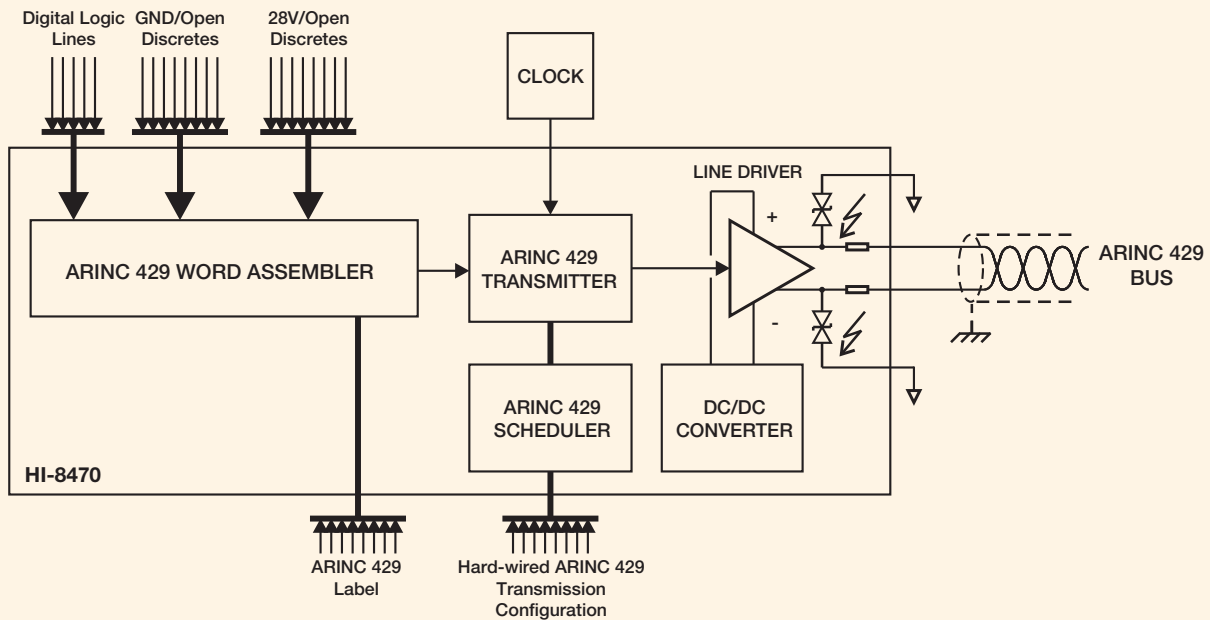

3.3V Dual Receiver, Single Transmitter Evaluation Board: ADK-35930

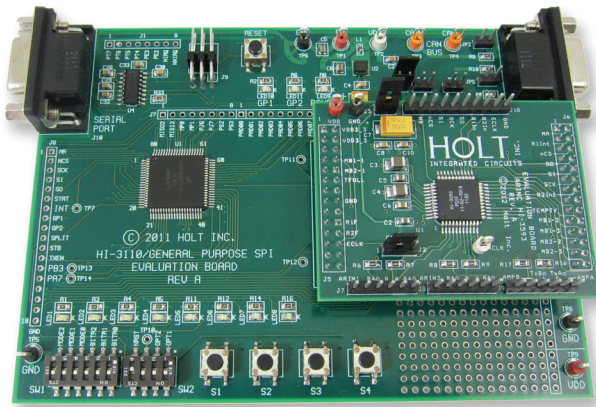

- Transmission and Reception of ARINC low speed and high speed messages
- Selectable ODD or EVEN parity
- Self Test mode (Internal digital loop back)
- 256 Receiver labels
- Receiver label reverse bit order
- Transmitter label reverse bit order
- Receiver Priority Label Mailboxes
- Receiver filter on SD9 or SD10
- ARINC ACLK programmable divider

ARINC 429 Data Management IC Evaluation Board: ADK-3220

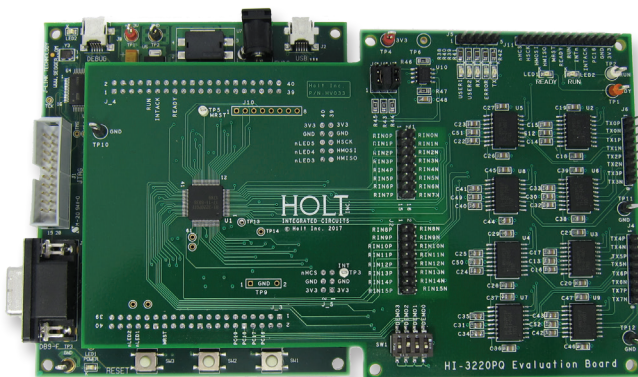

- 24-channel data management IC: Holt HI-3220
- Transmission scheduling
- Data Concentrator; receive messages on multiple channels and re-transmit on one channel
- Data Repeater; receive and re-transmit messages on same channel
- Tx FIFO data transmission direct from MCU
- Self-Test Loopback
- MCU board with (Microchip/Atmel) ARM Cortex M3 16-/32-bit microprocessor, debug interface and regulated 3.3VDC power supply

NOTES

- 1) “-15” or “-40” designates the use of external resistors for lightning protection of ARINC inputs. See datasheet and AN-300 & AN-301 for details of lightning protection on ARINC inputs and outputs.
- 2) Test Mode functions are part specific. See datasheet for details.
- 3) See IC Packages.
- 4) Contact your local sales representative for RoHS compliant (lead free) options.
- 5) **I:** -40°C to +85°C. **T:** -55°C to +125°C w/o burn in. **M:** -55°C to +125°C with burn in.
- 6) Dimensions refer to approximate footprint and height when mounted, “L x W x H”. Guideline only. Data sheet dimensions should be used for design purposes.
- 7) Parts with internal lightning protection allow compliance with RTCA/DO-160G, Section 22 Level 3 Pin Injection Test Waveform Set A (3 & 4), Set B (3 & 5A) and Set Z (3 & 5B). See Holt Application Notes AN-300 and AN-301 for further details on lightning protection of Holt ARINC 429 parts.
- 8) When powered down.
- 9) Galvanically isolated.

For further information on these and other Holt products contact:



Corporate Headquarters
101 Columbia
Aliso Viejo, CA 92656. USA
Phone: (949) 859-8800 Fax: (949) 859-9643
Email: sales@holtic.com Web: www.holtic.com

East Coast Office
740 Veterans Memorial Hwy.
Suite 205
Hauppauge, NY 11788. USA
Phone: (631) 343-7118



FM 661927 • AS9100D:2016 • ISO 9001:2015

HOLT-21619 2/23